



General Certificate of Secondary Education
2022

Centre Number

--	--	--	--	--

Candidate Number

--	--	--	--

GCSE Chemistry

Unit 2

Higher Tier

ML

[GCM22]

MONDAY 20 JUNE, MORNING

TIME

1 hour 30 minutes, plus your additional time allowance.

INSTRUCTIONS TO CANDIDATES

Write your Centre Number and Candidate Number in the spaces provided at the top of this page.

You must answer the questions in the spaces provided.

Do not write outside the boxed area on each page or on blank pages.

Complete in black ink only. **Do not write with a gel pen.**

Answer **all six** questions.

INFORMATION FOR CANDIDATES

The total mark for this paper is 100.

Figures in brackets printed down the right-hand side of pages indicate the marks awarded to each question or part question.

Quality of written communication will be assessed in Question **3(d)(iii)**.

A Data Leaflet, which includes a Periodic Table of the Elements, is included in this question paper.

- 1 Dilute hydrogen peroxide solution is a mild antiseptic which can be used on the skin to prevent infection of minor cuts. Hydrogen peroxide decomposes at room temperature and releases oxygen. The release of oxygen causes foaming which helps to remove dead skin and clean the cut.

(a) The equation for the decomposition of hydrogen peroxide may be written as:

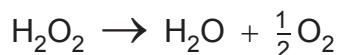

Calculate the volume of oxygen gas which is produced when 17 g of hydrogen peroxide completely decompose at 20 °C and 1 atm pressure. State the units.

volume = _____ [4]

(b) The diagram below shows some of the apparatus used in the laboratory to investigate the rate of reaction for the decomposition of hydrogen peroxide.

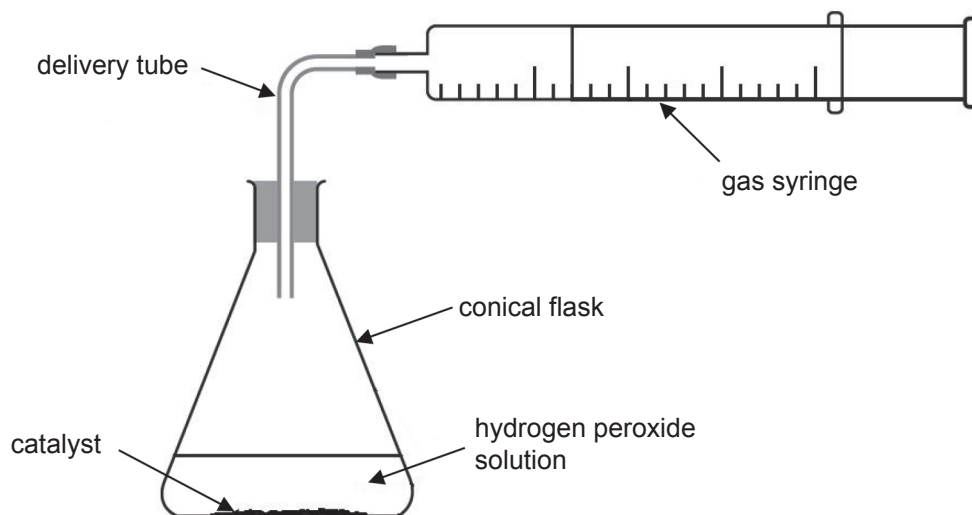

(i) Name one other piece of apparatus that the student must use in order to investigate the rate of reaction for the decomposition of hydrogen peroxide.

_____ [1]

(ii) Name a catalyst that can be used to increase the rate of decomposition of hydrogen peroxide.

_____ [1]

(iii) Explain how a catalyst increases the rate of the reaction.

_____ [2]

(iv) Explain why increasing the concentration of hydrogen peroxide solution will increase the rate of the reaction.

_____ [3]

[Turn over

(c) The results obtained from the experiment in (b) are shown in the table below.

Time /s	0	10	20	30	40	50	60	70	80	90
Volume of oxygen /cm ³	0	60	90	105	112	116	118	120	120	120

(i) Calculate the number of moles of oxygen collected in the first 20 seconds.

moles of oxygen = _____ [2]

(ii) Explain why the volume of gas did not increase beyond 120 cm³.

_____ [1]

- (d) Hydrogen peroxide may be manufactured by reacting barium peroxide, BaO_2 , with cold dilute sulfuric acid. The equation for the reaction is:



Calculate the percentage atom economy of hydrogen peroxide in this reaction. Give your answer to 1 decimal place.

percentage atom economy = _____ % [2]

- (e) Hydrogen peroxide may also be manufactured using hydrogen gas, oxygen from the air and a substance called anthraquinone (represented by the letter Q). It is a two-step reaction.

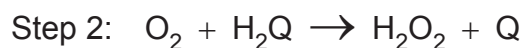
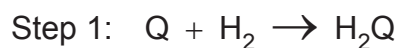

Suggest one advantage of manufacturing hydrogen peroxide using this method.

_____ [1]

[Turn over

- 2 Nitrogen monoxide reacts with oxygen to form nitrogen dioxide. This is shown in the equation below. A dynamic equilibrium is established.

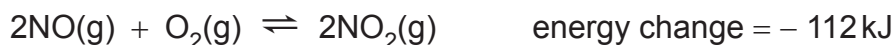

- (a) State two features of a dynamic equilibrium.

[2]

- (b) State and explain the effect of increasing pressure on the equilibrium yield of nitrogen dioxide.

[3]

- (c) The table below shows the percentage yield of nitrogen dioxide at different temperatures.

Temperature /°C	100	200	300	400
Percentage yield of NO ₂ at equilibrium /%	98	92	85	76

- (i) Look at the data in the table. Use it to write about the effect of an increase in temperature on the percentage yield of NO_2 .

[1]

- (ii) Explain the effect of an increase in temperature on the equilibrium yield of NO_2 .

[2]

- (d) On the axes below, draw a **labelled** reaction profile diagram for the reaction between nitrogen monoxide and oxygen forming nitrogen dioxide. The diagram should include the energy levels of the reactants and products, the energy change, a reaction pathway and the activation energy.

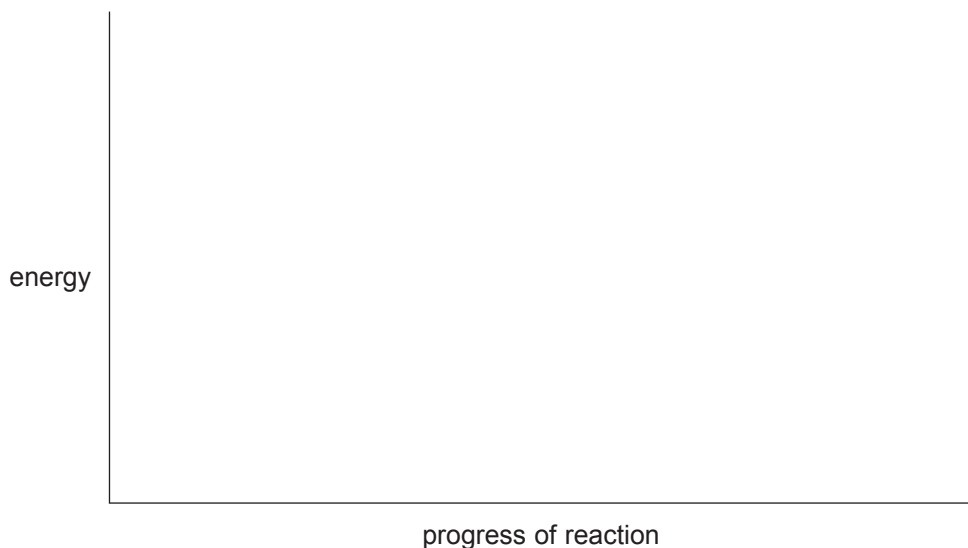

[4]

[Turn over

3 Organic compounds may be grouped into different homologous series.

(a) State two features of a homologous series of organic compounds.

[2]

(b) Complete the table below to give the functional group of some homologous series.

Homologous series	Functional group
alkenes	
alcohols	
carboxylic acids	

[3]

(c) Suggest why alkanes are less reactive than alkenes.

[1]

(d) Alcohols such as ethanol and propan-1-ol are colourless liquids.

(i) Draw the structural formulae of ethanol and propan-1-ol.

ethanol

propan-1-ol

[2]

(ii) Name another alcohol that has the same molecular formula as propan-1-ol.

[1]

(e) Propan-1-ol may be converted to propanoic acid. Propanoic acid reacts with metals such as magnesium.

(i) Name the reagent used to convert propan-1-ol to propanoic acid.

_____ [2]

(ii) What colour change is observed during the reaction of propan-1-ol with the reagent identified in (e)(i)?

_____ [1]

(iii) State the type of reaction occurring when propan-1-ol is converted to propanoic acid.

_____ [1]

(iv) Write a balanced symbol equation for the reaction of propanoic acid with magnesium.

_____ [3]

(v) What is observed when excess propanoic acid reacts with magnesium?

_____ [3]

[Turn over

- 4 A titration was carried out to find the concentration of a solution of sulfuric acid. 25.0 cm³ of 0.088 mol/dm³ aqueous sodium hydroxide were neutralised by 17.6 cm³ of dilute sulfuric acid.

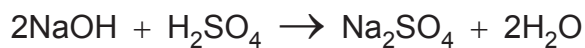

- (a) Name four essential pieces of equipment needed to carry out a titration. Do not include a retort stand and clamp,

[2]

- (b) Calculate the concentration of the sulfuric acid in mol/dm³.

concentration of sulfuric acid = _____ mol/dm³ [3]

- (c) Calculate the concentration of the sulfuric acid in g/dm^3 . Give your answer to 1 decimal place.

concentration of sulfuric acid = _____ g/dm^3 [2]

- (d) Hydrated sodium sulfate, $\text{Na}_2\text{SO}_4 \cdot x\text{H}_2\text{O}$, has a relative formula mass (M_r) of 322.

Calculate the value of x in $\text{Na}_2\text{SO}_4 \cdot x\text{H}_2\text{O}$

$x =$ _____ [2]

5 Nearly 75% of the elements in the Periodic Table are classified as metals. These metals show different reactivities.

(a) In an experiment, a small piece of metal was added to a fixed volume of water and the time taken for the reaction to finish was recorded. The results are shown in the table below.

Metal	Time taken for reaction to finish /s
calcium	42
lithium	35
magnesium	Not finished after 300 s
potassium	5
sodium	11

(i) Write a balanced symbol equation for the reaction of potassium with water.

_____ [3]

(ii) A few drops of phenolphthalein were added to the solution produced when potassium reacted with water. State the colour observed.

_____ [1]

(iii) Describe, in terms of electrons, what happens to the potassium atoms when they react with water.

_____ [2]

(iv) Compare the reactivity of Group 1 and Group 2 metals. Give evidence from the table to support your answer.

[2]

[Turn over

- (b) When a mixture of iron(III) oxide and aluminium powder is reacted in the apparatus shown below, a bright flame and sparks are observed. Molten iron is formed.

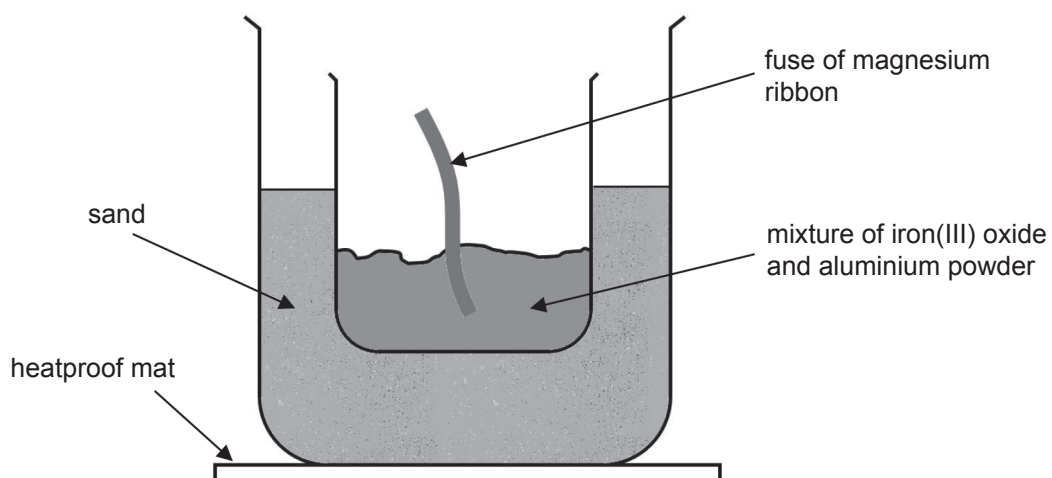

- (i) Write a balanced symbol equation for the reaction of iron(III) oxide with aluminium.

_____ [3]

- (ii) Explain, in terms of reactivity, why the reaction of iron(III) oxide with aluminium occurs.

_____ [1]

(c) Lead can be extracted from lead(II) oxide using carbon in a furnace. The word equation for the reaction is:

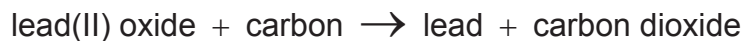

Explain fully, in terms of change in oxygen content, why this reaction is described as a redox reaction.

[5]

6 (a) Electrolysis occurs when molten sodium chloride conducts electricity.

(i) What does “electrolysis” mean?

_____ [1]

(ii) Explain why molten sodium chloride conducts electricity.

_____ [1]

(iii) What is observed at the anode?

_____ [2]

(iv) Name a suitable material used for the electrodes.

_____ [1]

(v) Write a half-equation for the reaction that occurs at the anode.

_____ [3]

(b) Dilute sulfuric acid also undergoes electrolysis.

(i) Name the electrolysis product at the cathode.

_____ [1]

(ii) Write a half-equation for the reaction that occurs at the anode.

_____ [3]

(c) Aluminium may be extracted from its ore by electrolysis. The ore of aluminium is purified in a series of reactions that produces solid aluminium hydroxide. The solid aluminium hydroxide is then heated to form aluminium oxide and water vapour is released. Aluminium oxide is dissolved in molten cryolite and the electrolysis is carried out.

(i) Name the ore from which aluminium is extracted.

_____ [1]

(ii) Write a balanced symbol equation for the reaction that occurs when solid aluminium hydroxide is heated. Include state symbols.

_____ [4]

(iii) State one reason why aluminium oxide is dissolved in molten cryolite.

_____ [1]

(iv) The half-equation for the reaction that occurs at the cathode is:



Explain why this reaction is a reduction reaction.

_____ [2]

THIS IS THE END OF THE QUESTION PAPER

DO NOT WRITE ON THIS PAGE

For Examiner's use only	
Question Number	Marks
1	
2	
3	
4	
5	
6	
Total Marks	

Examiner Number

Permission to reproduce all copyright material has been applied for.
In some cases, efforts to contact copyright holders may have been unsuccessful and CCEA will be happy to rectify any omissions of acknowledgement in future if notified.

SYMBOLS OF SELECTED IONS

Positive ions

Name	Symbol
Ammonium	NH_4^+
Chromium(III)	Cr^{3+}
Copper(II)	Cu^{2+}
Iron(II)	Fe^{2+}
Iron(III)	Fe^{3+}
Lead(II)	Pb^{2+}
Silver	Ag^+
Zinc	Zn^{2+}

Negative ions

Name	Symbol
Butanoate	$\text{C}_3\text{H}_7\text{COO}^-$
Carbonate	CO_3^{2-}
Dichromate	$\text{Cr}_2\text{O}_7^{2-}$
Ethanoate	CH_3COO^-
Hydrogencarbonate	HCO_3^-
Hydroxide	OH^-
Methanoate	HCOO^-
Nitrate	NO_3^-
Propanoate	$\text{C}_2\text{H}_5\text{COO}^-$
Sulfate	SO_4^{2-}
Sulfite	SO_3^{2-}



Data Leaflet

Including the Periodic Table of the Elements

For the use of candidates taking
 Science: Chemistry,
 Science: Double Award
 or Science: Single Award

Copies must be free from notes or additions of any kind. No other type of data booklet or information sheet is authorised for use in the examinations

SOLUBILITY IN COLD WATER OF COMMON SALTS, HYDROXIDES AND OXIDES

Soluble
All sodium, potassium and ammonium salts
All nitrates
Most chlorides, bromides and iodides EXCEPT silver and lead chlorides, bromides and iodides
Most sulfates EXCEPT lead and barium sulfates Calcium sulfate is slightly soluble
Insoluble
Most carbonates EXCEPT sodium, potassium and ammonium carbonates
Most hydroxides EXCEPT sodium, potassium and ammonium hydroxides
Most oxides EXCEPT sodium, potassium and calcium oxides which react with water

gcse examinations chemistry

